

2MP AHD HA-DVR-2116-L

- H.265 dual-stream video compression
- Supports AHD/HQA/CVI/TVI/CVBS video inputs
- Long transmission distance over coax cable
- Supports 1 SATA HDD, up to 8TB



Supercharge your security system with Honeywell's AHD recorder technology for High Definition 2 MP images over your existing coax infrastructure. Our newest AHD DVRs use an over-coaxial cable analog HD video transmission standard to allow long-distance HD transmission at a lower cost. The AHD 2MP DVRs are the economic alternative for achieving HD video surveillance while retaining your existing BNC cables and cameras.

SAFETY FEATURES

- Configurable motion detection and camera tamper detection settings, including configurable event notifications, such as automatic emails (with attached video or snapshot) and automatic alerts (such as buzzers).
- Remote configuration and firmware updating through Honeywell Viewer web client and the Honeywell Config tool. Password-protected access to the camera's and DVR's video and network setup.
- Bidirectional communication for the DVR.

EASY TO USE

- The Quick wizard and plug-and-play (like traditional DVRs and analog cameras) make setup fast and easy.
- Physical installation within minutes with the help of a comprehensive and easy-to-understand quick installation guide.

DYNAMIC, ACCESSIBLE MONITORING

- Monitor from anywhere using the mobile apps for iOS and Android devices.
- The DVR support feature of smart search (search for video that was recorded because motion was detected in a selected area).

MARKET OPPORTUNITIES

- The AHD 2MP DVRs' technology makes these recorder perfect for installations where you want HD-quality video while still using your existing coax infrastructure.
- These AHD DVRs also deliver higher quality video than current 960H analog systems, but at a similar cost.

FULLY-FEATURED DVRs



High decoding capability for full HD viewing.



H.265 video compression.



DVR supports multi format AHD/HQA/CVI/TVI/CVBS video input.



Simultaneous HDMI/VGA video output.

2MP AHD HA-DVR-2116-L Technical Specifications

SYSTEM	
Main Processor	Embedded Processor
Operating System	Embedded LINUX
VIDEO AND AUDIO	
Analog Camera Input	16 Channel, BNC
AHD Camera	1080P@25/30, 720P@25/30fps
CVBS Camera	PAL/NTSC
Audio In/Out	1/1, RCA
Two-way Talk	Reuse audio in/out, RCA
RECORDING	
Video Compression	H.265 / H.264
Resolution	1080N, 720P, 960H, D1, CIF
Record Rate	Main Stream: 1 st channel 1080N/720P(1~25/30fps), Other Channels 1080N/720P(1~15fps); 960H/D1/CIF (1~25/30fps) Sub Stream: CIF (1~7fps)
Video Bit Rate	32Kbps ~ 4096Kbps Per Channel
Record Mode	Manual, Schedule (General, Continuous), MD (Video detection: Motion Detection, Video Loss, Tampering), Alarm, Stop
Record Interval	1 ~ 60 min (default: 60 min), Pre-record: 1 ~ 30 sec, Post-record: 10 ~ 300 sec
Audio Compression	AAC (only for the 1 st channel), G.711A, G.711U, PCM
Audio Sample Rate	8KHz, 16 bit Per Channel
Audio Bit Rate	64Kbps Per Channel
DISPLAY	
Interface	1 HDMI, 1 VGA
Resolution	1920×1080, 1280×1024, 1280×720
Multi-screen Display	1/4/8/9/16
OSD	Camera title, Time, Video loss, Camera lock, Motion detection, Recording
NETWORK	
Ethernet	1 RJ-45 Port (100 Mbps)
Network Function	HTTPS; TCP/IP; IPv4/IPv6; UPnP; RTSP; UDP; SMTP; NTP; DHCP; DNS; IP filter; PPPoE; DDNS; FTP
Max. User Access	128 users
Mobile Device Compatibility	iPhone, iPad, Android (phone and tablet)
Interoperability	ONVIF Conformant

VIDEO DETECTION AND ALARM	
Trigger Events	Recording, PTZ, Tour, Email, FTP, Snapshot, Buzzer and Screen Tips
Video Detection	Motion Detection Video Loss, Tampering and Diagnosis
PLAYBACK AND BACKUP	
Playback	1/4/9/16
Search Mode	Time/Date; Alarm; Motion Detection; Exact Search (accurate to a second); Smart Search
Playback Function	Play, Pause, Stop, Rewind, Fast play, Slow Play, Next File, Previous File, Next Camera, Previous Camera, Full Screen, Repeat, Shuffle, Backup Selection, Digital Zoom
Backup Mode	USB Device/Network
STORAGE	
Internal HDD	1 SATA Port, up to 8TB capacity
AUXILIARY INTERFACE	
USB	2 USB 2.0
RS485	1 Port, for PTZ Control
ELECTRICAL	
Power Supply	DC12V/1.5A
Power Consumption (without HDD)	<10W
PHYSICAL	
Dimensions	260×236×48mm(10.2"×9.3"×1.9")
Net Weight(without HDD)	0.9kg (2.0lb)
ENVIRONMENTAL	
Operating Conditions	-10°C ~ +45°C (+14°F ~ +113°F), 10~ 90% RH
Storage Conditions	-20°C ~ +70°C (-4°F ~ +158°F), 0~ 90% RH
CERTIFICATIONS	
Certifications	BIS certified

Ordering Information

TYPE	PART NUMBER	DESCRIPTION
16 Channel DVR	HA-DVR-2116-L	16ch, 2MP DVR, 1 SATA, H.265

Dimensions (mm)

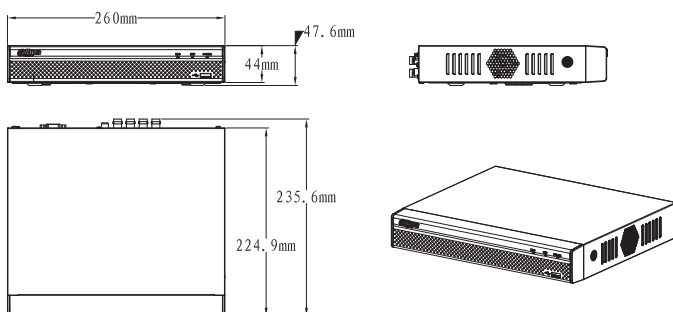

Rear Panel

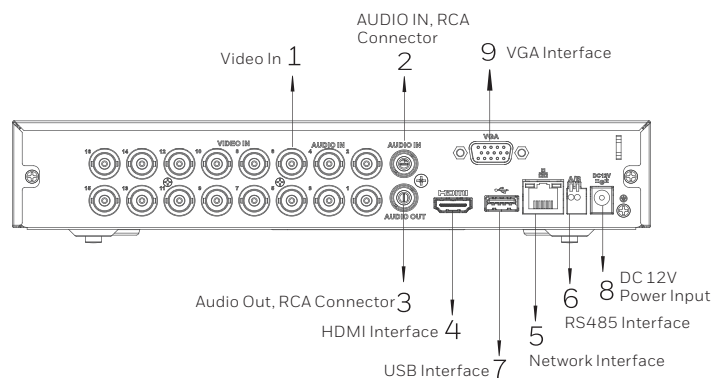

For more information

www.partnerconnect.honeywell.com

Call: 1-800-103-0339

Email: HoneywellSecurity&Fire@honeywell.com

Honeywell Building Technologies

Unitech Trade Center, 5th Floor, Sector 43

Block C, Sushant Lok Phase - 1,

Gurgaon 122002, Haryana, India

www.honeywell.com

2MP AHD HA-DVR-2116-L-DS | Rev01 | 03/20
© 2020 Honeywell International Inc.

**THE
FUTURE
IS
WHAT
WE
MAKE IT**

Honeywell